

BNC STRAIGHT CRIMP/CRIMP PLUG

10-005-W126-FA

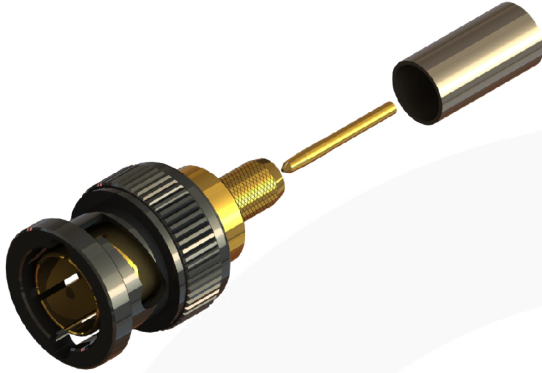

images for illustration purposes only

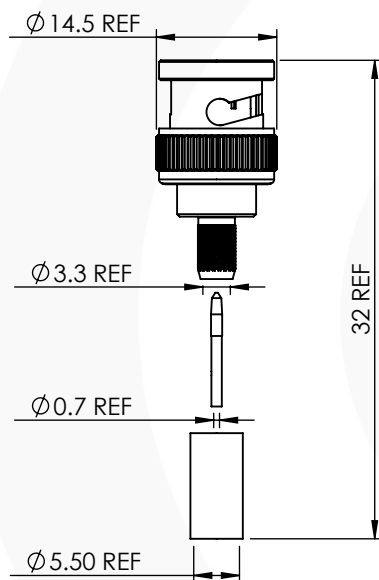

Suitable for Cables:

(FA) Belden 1855ENH, Draka 0.6/2.8AF, Bryant BD SD01, Image 360, Percon VK5, Condufil 9890, Draka Ultra HD Pro 50 UHD

Stripping Dimensions

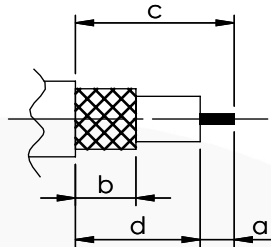

a = 4.0 mm
b = 8.0 mm
c = 16.0 mm
d = 12.0 mm

* CUT FOIL TO DIM. "b"

Assembly Procedure: AP001

Tooling

Centre Contact: SQ 0.95mm A/F Tool No: 96-HTS-75A

Crimp Sleeve: HEX 5.41mm A/F Tool No: 96-HTS-75A

Alignment Tool: Not Applicable Extraction: 96-2208

Environmental Specification

Operating Temp: -55 to +155 Deg C.

IP Rating (Mated): IP 64

Electrical Specification

Impedance: 75 Ohm

Frequency: 0-18 GHz

Dielectric W/V: 1500 Veff

Insulation res: 5000 M-Ohm

Mechanical Specification

Contact Retention: 10 N min

Cable Retention: 100 N min

Mating cycles: 500

Weight: 11.04 g

Connector Interface

image for illustration purposes only

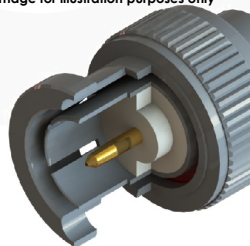

Performance

-29.97 dB @ 3.0 GHz

-26.59 dB @ 6.0 GHz

-24.32 dB @ 9.0 GHz

-19.85 dB @ 12.0 GHz

Return Loss Graph

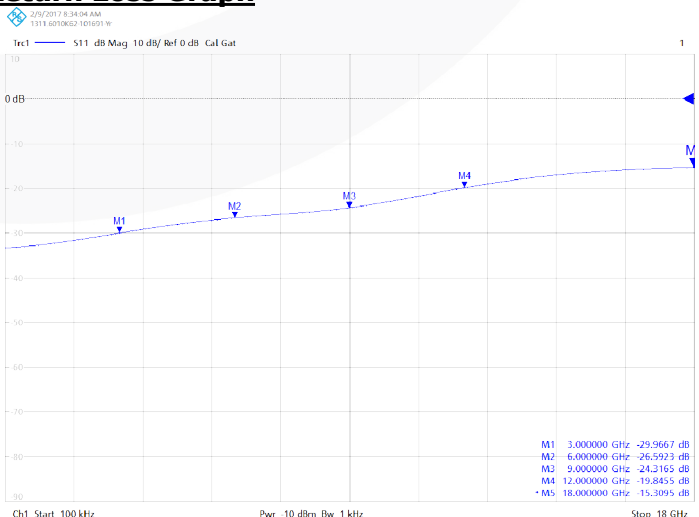

| 7 | WASHER | SK5 | NICKEL |
|------|----------------|----------|--------------|
| 6 | BAYONET CAP | BRASS | BLACK NICKEL |
| 5 | CRIMP SLEEVE | BRASS | NICKEL |
| 4 | GASKET | SILICONE | N/A |
| 3 | CENTRE CONTACT | BeCu | GOLD |
| 2 | INSULATOR | PTFE | N/A |
| 1 | BODY | BRASS | GOLD |
| ITEM | DESCRIPTION | MATERIAL | PLATING |

| | | | | |
|---|--------------|-------------------------------|-----------|-----------|
| A4 | SHEET 1 OF 1 | DIMENSIONS ARE IN MILLIMETRES | | |
| REVISION : | A07 | NAME | SIGNATURE | DATE |
| ISSUE : | 7 | DRAWN | GE | 07-Nov-13 |
| | | CHK'D | IG | 07-Nov-13 |
| | | APPV'D | | |
| 6-8 COLNE ROAD, TWICKENHAM, MIDDLESEX. TW1 4JR | | | | |
| THE INFORMATION IS GIVEN AS AN INDICATION ONLY AND IS SUBJECT TO CHANGE WITHOUT NOTICE. IN THE CONTINUAL GOAL TO IMPROVE OUR PRODUCTS, WE RESERVE THE RIGHT TO MAKE ANY MODIFICATIONS NECESSARY WITHOUT PRIOR NOTICE. | | | | |