

## BNC STRAIGHT CRIMP/CRIMP PLUG 10-005-A3-AH

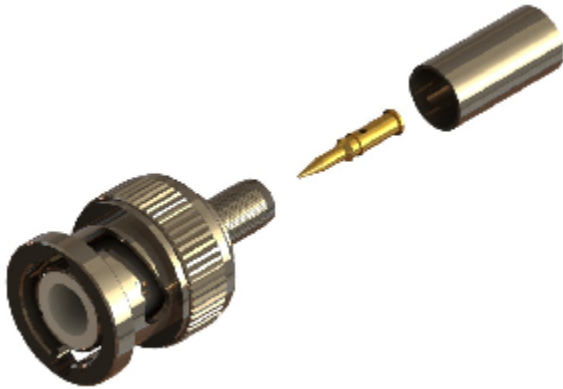

images for illustration purposes only

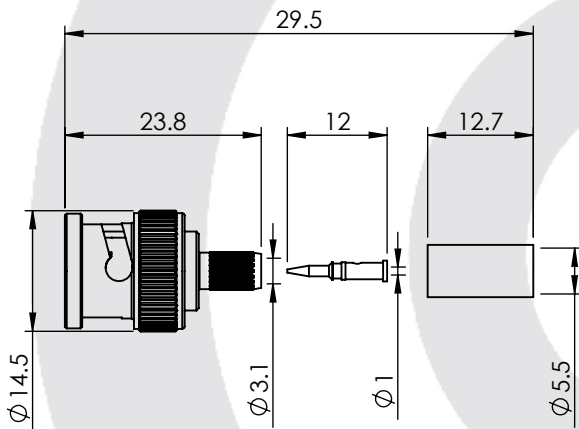

### Suitable for Cables:

(AH) RG58, RG141, LMR195, URM43, URM76, WBC195, PSF 1/6, KX15, KX23

### Stripping Dimensions

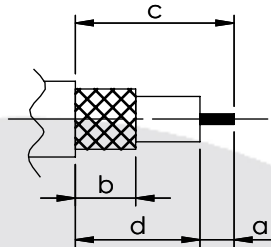

a = 4.0 mm  
b = 8.0 mm  
c = 16.0 mm  
d = 12.0 mm

### Assembly Procedure: AP001

### Tooling

Centre Contact: Hex 1.72mm A/F Tool No: 336A

Crimp Sleeve: Hex 5.41mm A/F Tool No: 336A

Alignment Tool: Not Applicable Extraction: 96-2208

### Environmental Specification

Operating Temp: -30 to +70 Deg C.

IP Rating (Mated): IP 64

### Electrical Specification

Impedance: 50 Ohm

Frequency: 0-3 GHz

Dielectric W/V: 1500 Veff

Insulation res: 5000 M-Ohm

### Mechanical Specification

Contact Retention: 10 N min

Cable Retention: 200 N min

Mating cycles: 100

Weight: 9.79 g

### Connector Interface

image for illustration purposes only

### Performance

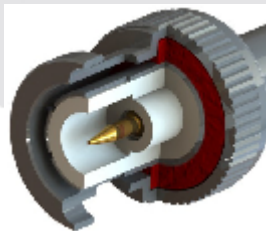

-29.5 dB @ 0.5 GHz  
-26.9 dB @ 1.0 GHz  
-24.3 dB @ 2.0 GHz  
-23.2 dB @ 3.0 GHz

### Return Loss Graph

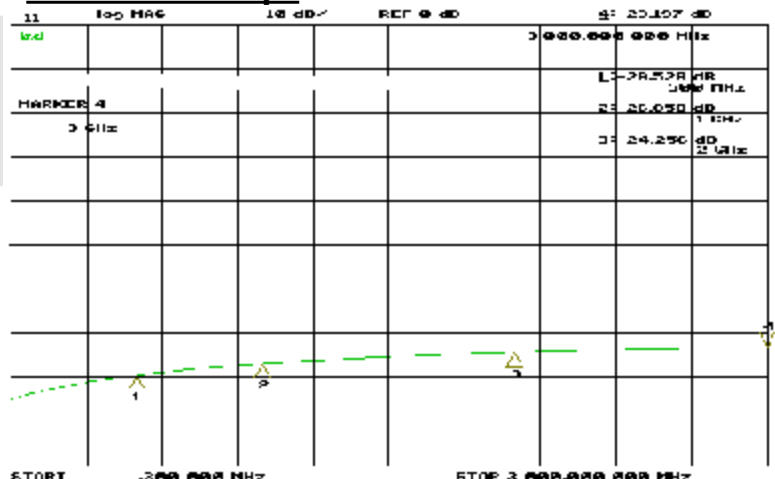

9	CRIMP SLEEVE	BRASS	NICKEL
8	CENTRE CONTACT	BRASS	GOLD
7	BODY	BRASS	NICKEL
6	WASHER	Fe	NICKEL
5	SPRING	SK5	NICKEL
4	RETAINING RING	SK5	NICKEL
3	GASKET	SILICONE	N/A
2	INSULATOR	DELFIN	N/A
1	COUPLING NUT	DIECAST ZINC	NICKEL
ITEM	DESCRIPTION	MATERIAL	PLATING

<b>A4</b>	SHEET 1 OF 1	DIMENSIONS ARE IN MILLIMETRES		
REVISION :	A01	NAME	SIGNATURE	DATE
ISSUE :	3	DRAWN	GE	19/09/2011
		CHK'D	IG	19/09/2011
		APP'D		
6-8 COLNE ROAD, TWICKENHAM, MIDDLESEX. TW1 4JR				
THE INFORMATION IS GIVEN AS AN INDICATION ONLY AND IS SUBJECT TO CHANGE WITHOUT NOTICE. IN THE CONTINUAL GOAL TO IMPROVE OUR PRODUCTS, WE RESERVE THE RIGHT TO MAKE ANY MODIFICATIONS NECESSARY WITHOUT PRIOR NOTICE.				