

## 1.0/2.3 STRAIGHT CRIMP/CRIMP PLUG 52-005-B6-FR

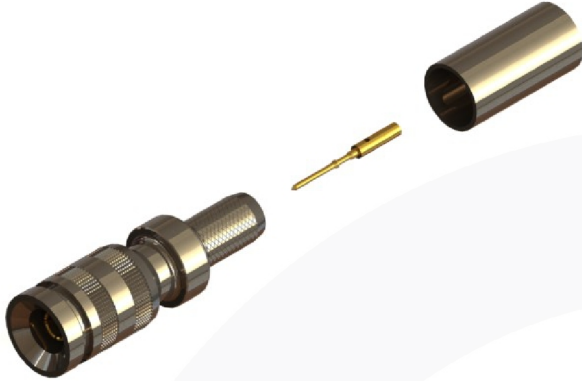

images for illustration purposes only

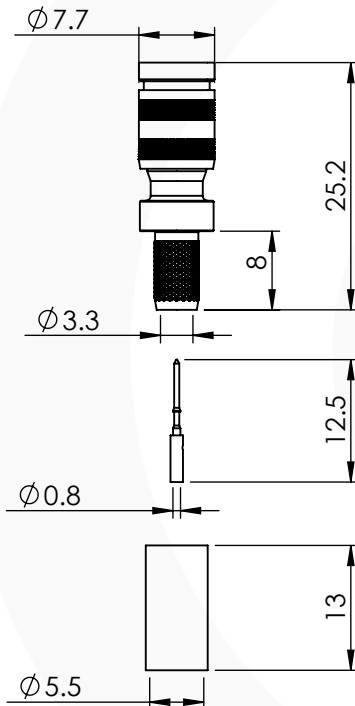

### Suitable for Cables:

(FR) SDV-UHD-LFH, Draka Ultra HD Pro 50 UHD

### Stripping Dimensions

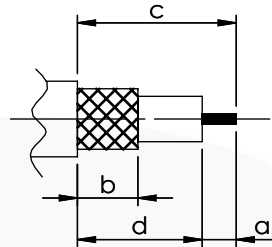

a = 4.0 mm  
\* b = 8.0 mm  
c = 16.0 mm  
d = 12.0 mm

\* STRIP FOIL  
SCREEN TO  
DIM "b"

### Assembly Procedure: AP026

### Tooling

Centre Contact: SQ 0.95mm A/F Tool No: 96-HTS-75A

Crimp Sleeve: Hex 5.41mm A/F Tool No: 96-HTS-75A

Alignment Tool: 100-1023 Extraction: 96-1023

### Environmental Specification

Operating Temp: -55 to +155 Deg C.

IP Rating (Mated): IP 40

### Electrical Specification

Impedance: 75 Ohm

Frequency: 0-12 GHz

Dielectric W/V: 750 Veff

Insulation res: 5000 M-Ohm

### Mechanical Specification

Contact Retention: 10 N min

Cable Retention: 100 N min

Mating cycles: 500

Weight: 5.03 g

### Connector Interface

image for illustration purposes only

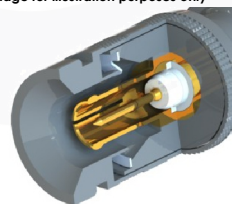

| ITEM | DESCRIPTION    | MATERIAL         | PLATING |
|------|----------------|------------------|---------|
| 8    | REAR BODY      | BRASS            | NICKEL  |
| 7    | OUTER CONTACT  | BERYLLIUM COPPER | GOLD    |
| 6    | CENTRE CONTACT | PHOSPHOR BRONZE  | GOLD    |
| 5    | SPRING         | STAINLESS STEEL  | NICKEL  |
| 4    | CRIMP SLEEVE   | BRASS            | NICKEL  |
| 3    | BODY           | BRASS            | NICKEL  |
| 2    | INSULATOR      | PTFE             | N/A     |
| 1    | COUPLING NUT   | BRASS            | NICKEL  |

|   |              |        |                               |           |  |
|---|--------------|--------|-------------------------------|-----------|--|
| <b>A4</b>   | SHEET 1 OF 1 |        | DIMENSIONS ARE IN MILLIMETRES |           |  |
| REVISION :  | A00          |        | NAME                          | SIGNATURE | DATE   |
| ISSUE :   | 1            |        | DRAWN                         | G.E.      | 28/07/2022   |
|   |              |        | CHK'D                         | P.S.      | 28/07/2022   |
| <b>6-8 COLNE ROAD,<br/>TWICKENHAM,<br/>MIDDLESEX.<br/>TW1 4JR</b> |              | APPV'D |                               |           | <small>THE INFORMATION IS GIVEN AS AN INDICATION ONLY AND IS SUBJECT TO CHANGE WITHOUT NOTICE. IN THE CONTINUAL GOAL TO IMPROVE OUR PRODUCTS, WE RESERVE THE RIGHT TO MAKE ANY MODIFICATIONS NECESSARY WITHOUT PRIOR NOTICE.</small> |